

Bördeln im Behälter- und Apparatebau

Flanging in tank and vessel building

MZ 20 , MZ 30
MKF 130/16
MKF 140/32

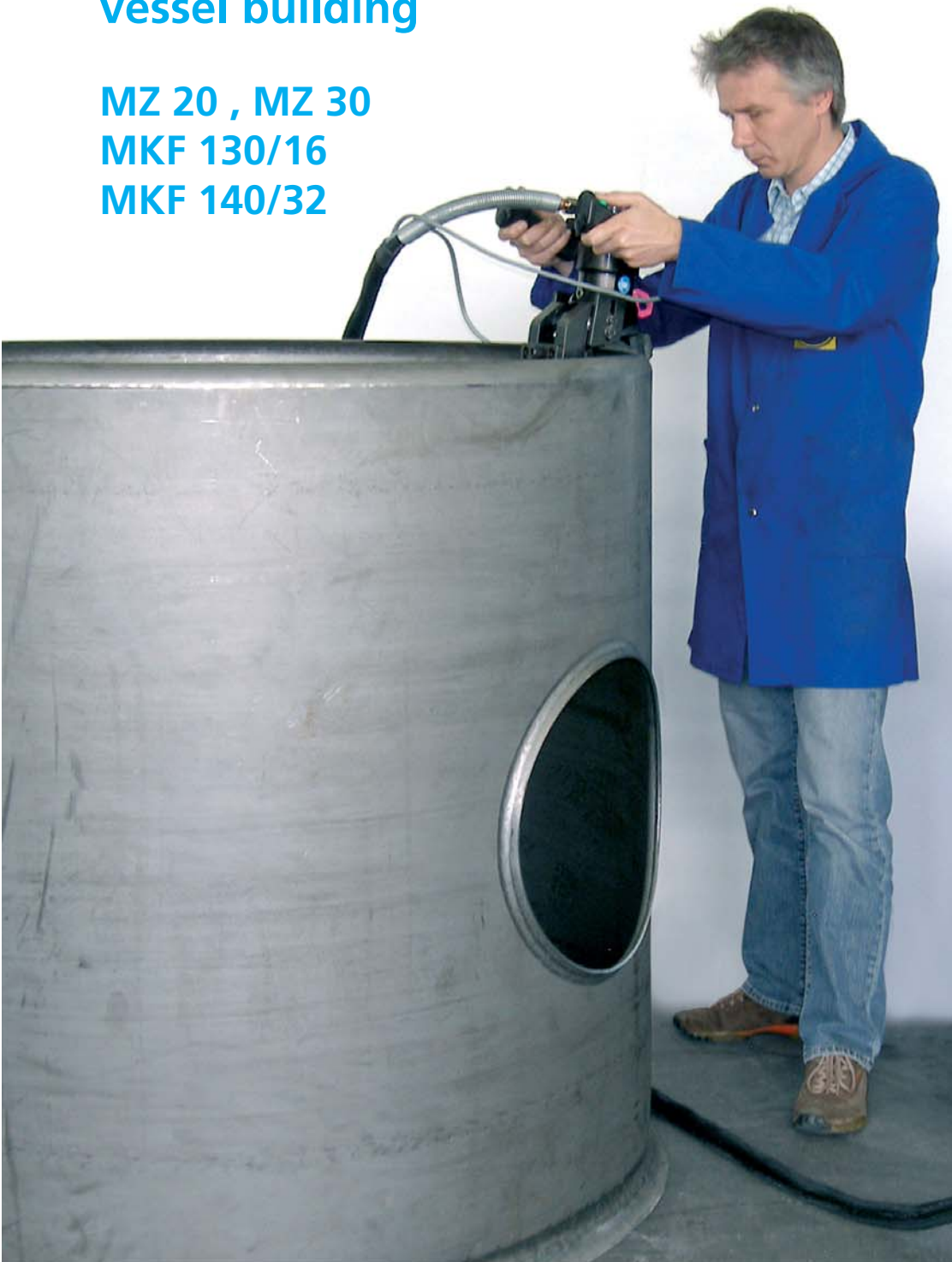

® for sheet metal
and profiles

.....
Swiss precision

Wirtschaftlicher Umformen

flexibel und umweltfreundlich

Forming in a more economical way

and without harming to the environment

Die Problematik The Problem

Im heutigen Apparate- und Behälterbau werden Umformarbeiten zum Teil immer noch unter Erwärmung der Umformzone und manuell mit dem Hammer ausgeführt.

Nachteil dieser Methode:

- hohe Lärmbelastigung
- gesundheitliche Belastung für den Werker
- hoher Aufwand an Nacharbeit, der sehr kostenintensiv und zeitaufwendig ist

Forming operations in today's Tank and Vessel manufacture is still partly done by using heat and hammers on the areas to be formed – especially on large and bulky parts.

Disadvantages of this method:

- High noise level
- Dangerous to health
- Finishing cumbersome, time consuming and thus expensive

Die Lösung The solution

ECKOLD-Mobilformer bringen keinen der genannten Nachteile mit sich. Mobile, freibewegliche Geräte schaffen Flexibilität beim Bördeln, Aushalsen, Richten und Anpassen und sind durch den hydraulischen Antrieb äußerst geräuscharm. Schnell austauschbare Werkzeugeinsätze sichern den universellen Einsatz. Sie werden dem konkreten Bearbeitungsproblem genau angepasst.

ECKOLD Portable units eliminate the above mentioned problems. These offer flexibility for flanging, neckforming, straightening and correcting. The mobile hydraulic drive considerably reduces the noiselevel, and by utilising quick change inserts to suit the application in hand, the portable tools are universal and still give excellent results.

Die Anlage The unit

Eine Mobilformer-Anlage besteht aus dem hydraulischen Antriebsaggregat, einer mobilen Zange oder einem Bügel und den Werkzeugen.

Zusätzlichen Spielraum schafft eine Reihe von Grundgeräten mit Druckkräften von 50 kN bis 320 kN.



A complete Mobil-former unit consists of Portable tool, quick change inserts and hydraulic drive unit.

There are several tools available with pressure forces from 50 kN to 320 kN.

Die Vorteile The advantages

- flexible Anwendung
- universeller Einsatz
- umweltfreundliche Kaltumformung
- kostengünstige Produktion

- flexible application
- universal use
- clean forming without heat
- production at low cost

Eigenschaften Characteristics

Es ist Zeit Hammer und Flamme beiseite zu legen, wenn es um die Randzonenbearbeitung von Behältern, Konen und Böden geht. ECKOLD-Systeme, wie die Mobilformer, bieten zahlreiche Eigenschaften zur Optimierung im Behälter- und Apparatebau.

It is time to put hammer and flame to rest when working on rim areas of vessels, cones and bottoms. ECKOLD systems like the Mobilformer offer numerous advantages to optimise tank and vessel production.

- geringe Rüstzeiten
- geringe Fertigungszeiten
- mobil mit dem Gerät zum Bauteil
- vorrichtungsunabhängig
- baustellengeeignet für Montage
- Einmann-Bedienung
- geräuscharm

- min. set-up time
- quick production
- mobile application – move the tool not the workpiece
- no fixtures required
- can be used on site
- one man operation
- low noise level



Anwendungsbereiche Range of application

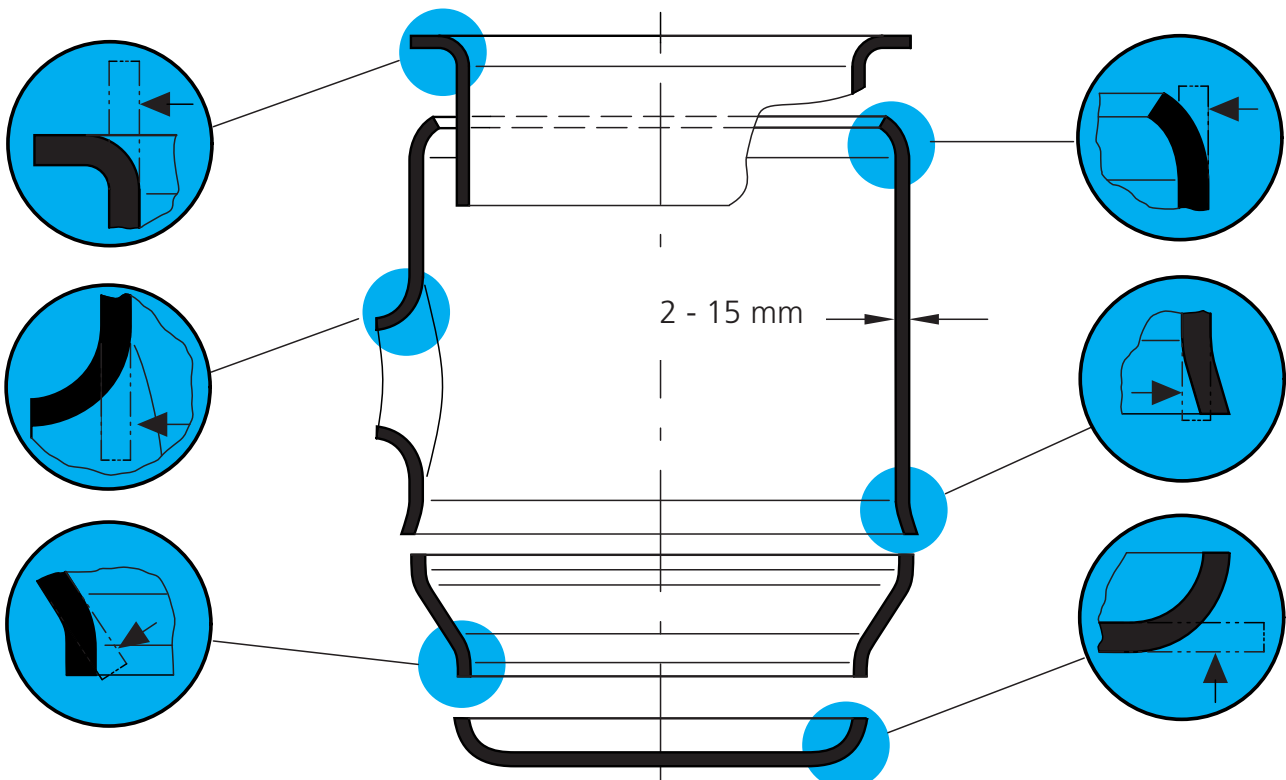

Mobile Zange Mobile pliers

Geeignet zum Bördeln von Zylindern, Böden, Kegeln, zum Aushalsen sowie zum Anpassen. Mit 6 m Hochdruck-Hydraulikschlauch und 2-Hand-Sicherheitsauslösung (ohne Einsätze).

Suitable for flanging cylinders, bottoms and cones as well as for neckforming on manholes and for adjusting and correcting. Complete with 6 m high-pressure hydraulic hose and 2-hand safety release (without inserts).

MZ 20

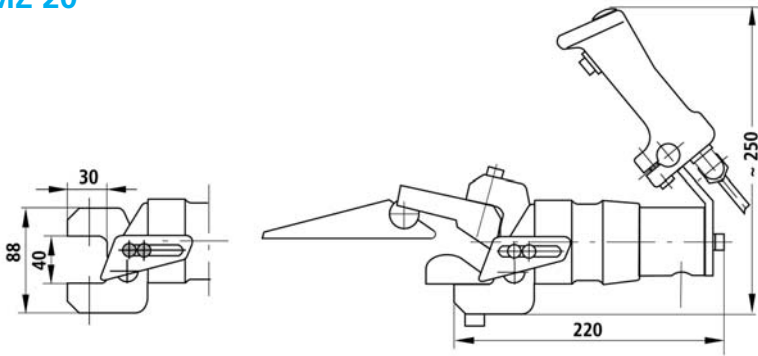

Typ / type:	MZ 20
Bestell-Nr. / Order no.:	012.020.0010
Ident-Nr.:	000 0007 9676
Gewicht / weight:	~ 9 kg
Druckkraft / pressure force:	max. 50 kN
Blechdicke / sheet thickness:	
St-Qualität / m/s-quality	2.0 – 4.0 mm
Edelstahl / stainless steel	2.0 – 3.0 mm



MZ 30

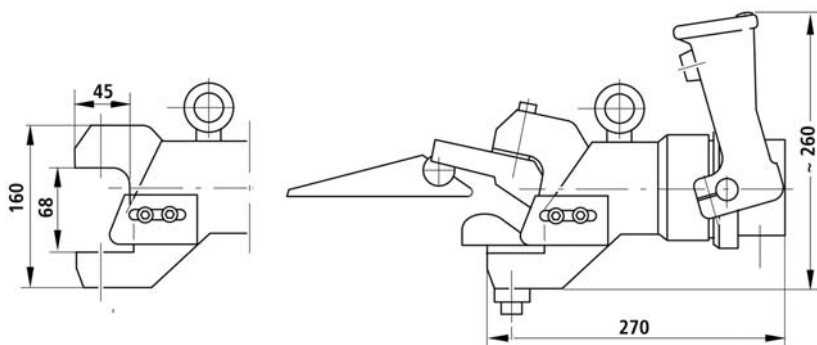

Typ / type:	MZ 30
Bestell-Nr. / Order no.:	012.020.0110
Ident-Nr.:	000 0000 4013
Gewicht / weight:	~ 20 kg
Druckkraft / pressure force:	max. 120 kN
Blechdicke / sheet thickness:	
St-Qualität / m/s-quality	3.0 – 7.0 mm
Edelstahl / stainless steel	3.0 – 5.0 mm



Mobiler Kraftformer

Geeignet zum Bördeln von Zylindern, Böden, Kegeln sowie zum Anpassen.
Mit 6 m Hochdruck-Hydraulikschlauch und 2-Hand-Sicherheitsauslösung (ohne Einsätze).

Mobile Kraftformer

Suitable for flanging on cylinders, bottoms, cones as well as for adjusting or correcting. Complete with 6 m high-pressure hydraulic hose and 2-hand safety release (without inserts).

MKF 130/16

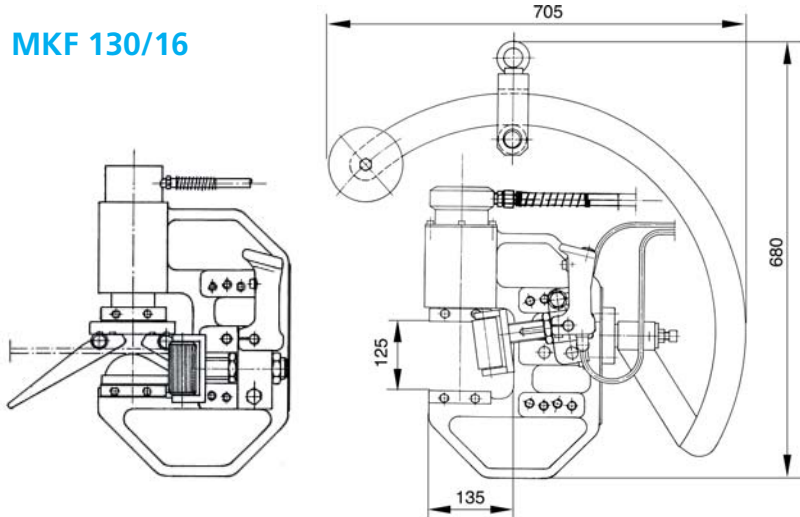

Typ / type:	MKF 130/16
Bestell-Nr. / Order no.:	012.020.0210
Ident-Nr.:	000 0000 3297
Gewicht / weight:	~ 80 kg
Druckkraft / pressure force:	max. 160 kN

Blechdicke / sheet thickness:	
St-Qualität / m/s-quality	4.0 – 10.0 mm
Edelstahl / stainless steel	4.0 – 8.0 mm

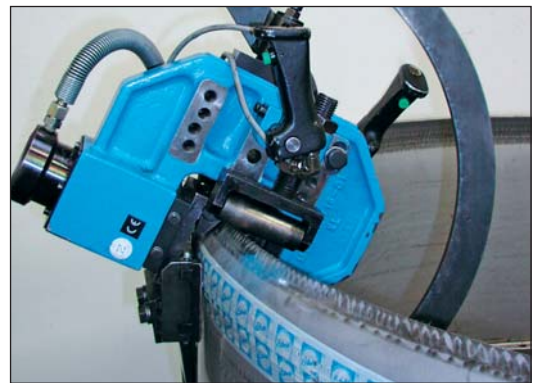
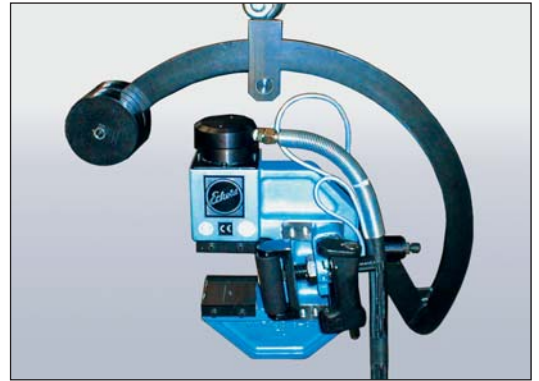

MKF 140/32

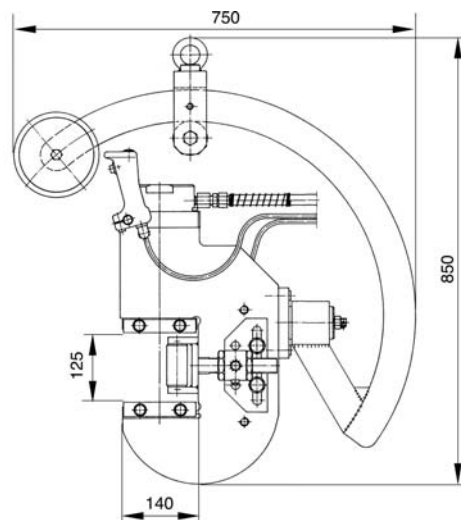

Typ / type:	MKF 140/32
Bestell-Nr. / Order no.:	012.020.0310
Ident-Nr.:	000 0000 9124
Gewicht / weight:	~ 130 kg
Druckkraft / pressure force:	max. 320 kN

Blechdicke / sheet thickness:	
St-Qualität / m/s-quality	6.0 – 15.0 mm
Edelstahl / stainless steel	6.0 – 12.0 mm



Bördeleinsätze Flanging inserts

Auswechselbare Bördeleinsätze zum Bördeln nach innen von Zylindern, Kegeln, Böden und zum Anpassen, bestehend aus einem Oberteil (1) mit langer Schwenkplatte und einem Unterteil (2).

MZ 20

MZ 30

MKF 130/16

MKF 140/32

Interchangeable flanging inserts consisting of top part (1) with long swivel plate and bottom part (2), designed for flanging to the inside on cylinders, cones and bottoms and for adjusting work.

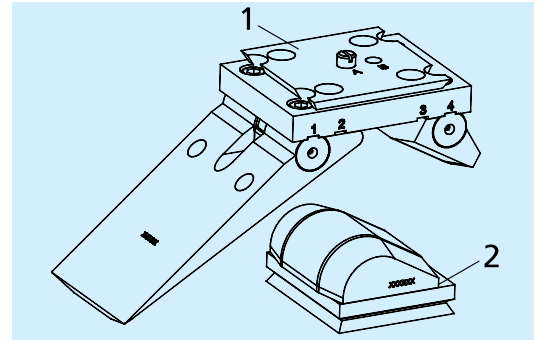
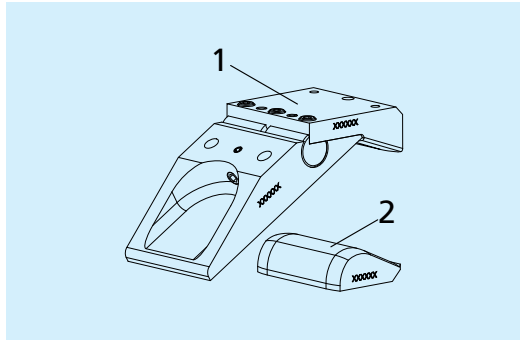

Bördeleinsätze MZ 20 , MZ 30
Flanging inserts MZ 20 , MZ 30

Bördeleinsätze MKF 130/16 , MKF 140/32
Flanging inserts MKF 130/16 , MKF 140/32

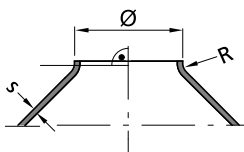
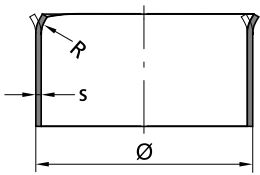
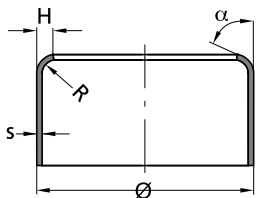

Bördeleinsatz Flanging insert	Bestell-Nr. Order no.	Ident-Nr. Ident-No.	ø [mm]	R [mm]	H max. [mm]	α	S [mm]	
							Stahl /Steel (400 N/mm ²)	Inox./s.s. (600 N/mm ²)
MZ 20	012.210.0005	0000 004 7318	500 - ∞	15	20	≤ 80°	2.0 - 4.0	2.0 - 3.0
MZ 20	012.210.0006	0000 001 4699	500 - ∞	20	25	≤ 80°	2.0 - 4.0	2.0 - 3.0
MZ 30	012.210.0015	0000 004 3976	800 - ∞	25	30	≤ 80°	3.0 - 7.0	3.0 - 5.0
MZ 30	012.210.0016	0000 002 2906	800 - ∞	30	35	≤ 80°	3.0 - 7.0	3.0 - 5.0
MZ 30	012.210.0017	0000 004 7321	800 - ∞	40	35	≤ 70°	3.0 - 7.0	3.0 - 5.0
MKF 130/16	012.210.0026	0000 004 7394	1200 - ∞	30	40	≤ 80°	4.0 - 10.0	4.0 - 8.0
MKF 130/16	012.210.0027	0000 004 7393	1200 - ∞	50	45	≤ 80°	4.0 - 10.0	4.0 - 8.0
MKF 130/16	012.210.0028	0000 004 7392	1200 - ∞	80	45	≤ 45°	4.0 - 10.0	4.0 - 8.0
MKF 140/32	012.210.0036	0000 000 9202	1500 - ∞	50	55	≤ 45°	6.0 - 15.0	6.0 - 12.0
MKF 140/32	012.210.0037	0000 002 0155	1500 - ∞	100	55	≤ 45°	6.0 - 15.0	6.0 - 12.0

Niederhalter (3). Zum Bördeln von Böden, flachen Kegeln oder Konturblechen.

Pressure pad (3). For flanging on bottoms, flat cones or profiled sheets.

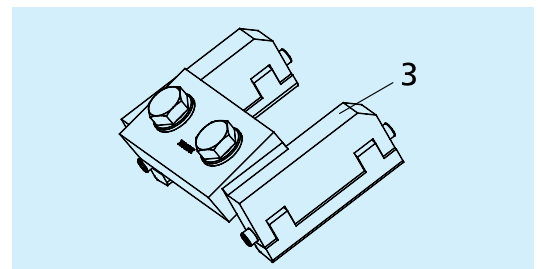
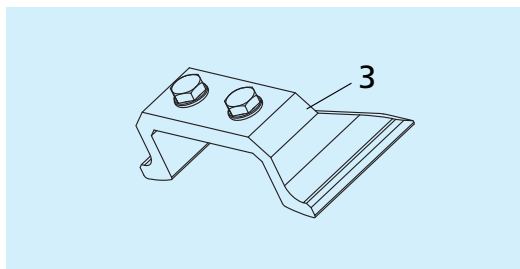
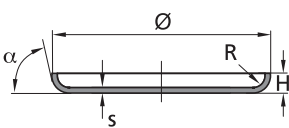
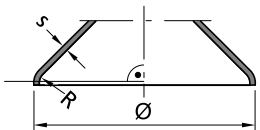

Niederhalter Pressure pad	Bestell-Nr. Order no.	Ident-Nr. Ident-No.
MZ 20	012.210.0800	0000 000 3153
MZ 30	012.210.0810	0000 000 2957

Niederhalter Pressure pad	Bestell-Nr. Order no.	Ident-Nr. Ident-No.
MKF 130/16	012.210.0820	0020 302 5102
MKF 140/32	012.210.0830	0020 303 5105

Bördeleinsätze
Flanging inserts

Bördeleinsätze für flanschartiges Bördeln nach aussen (auf Anfrage).

Flanging inserts for flanging to the outside available on request.

MZ 20

MZ 30

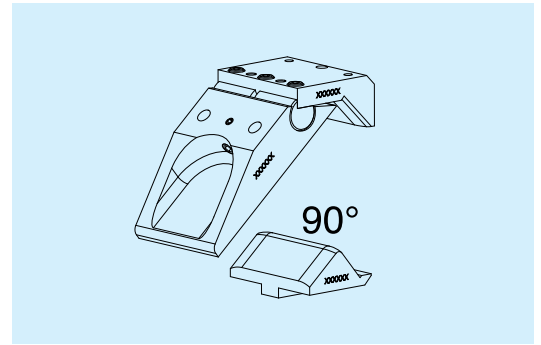
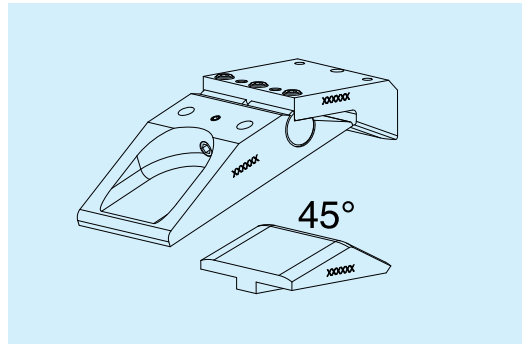
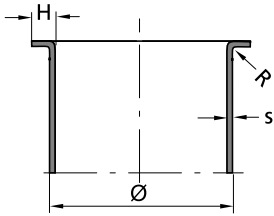

Bördeleinsatz 45° Flanging insert 45°	Bestell-Nr. Order no.	Ø [mm]	H max. [mm]
MZ 20	auf Anfrage on request	≤ 500	-
MZ 30	auf Anfrage on request	≤ 800	-

Bördeleinsatz 90° Flanging insert 90°	Bestell-Nr. Order no.	Ø [mm]	H max. [mm]
MZ 20	auf Anfrage on request	≤ 500	25
MZ 30	auf Anfrage on request	≤ 800	30

Bördeleinsätze
Flanging inserts

Bördeleinsätze für das Bördeln (Aushalsen) von Mannlöchern (auf Anfrage).

Flanging inserts for manholes (neck-forming) on request.

MZ 20

MZ 30

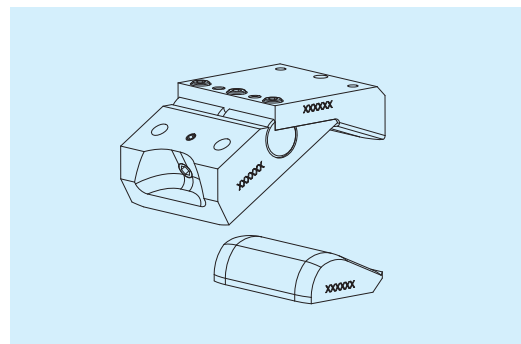
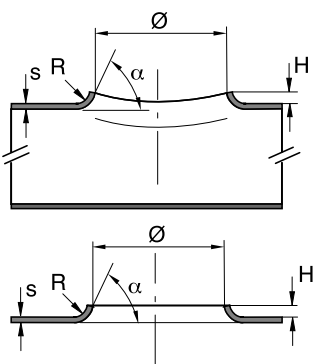

Bördeleinsatz Flanging insert	Bestell-Nr. Order no.	Ø [mm]	H max. [mm]
MZ 20	auf Anfrage on request	≤ 400	~15*
MZ 30	auf Anfrage on request	≤ 500	~15*

* in Abhängigkeit von s, Ø, R und α
* depending on s, Ø, R and α

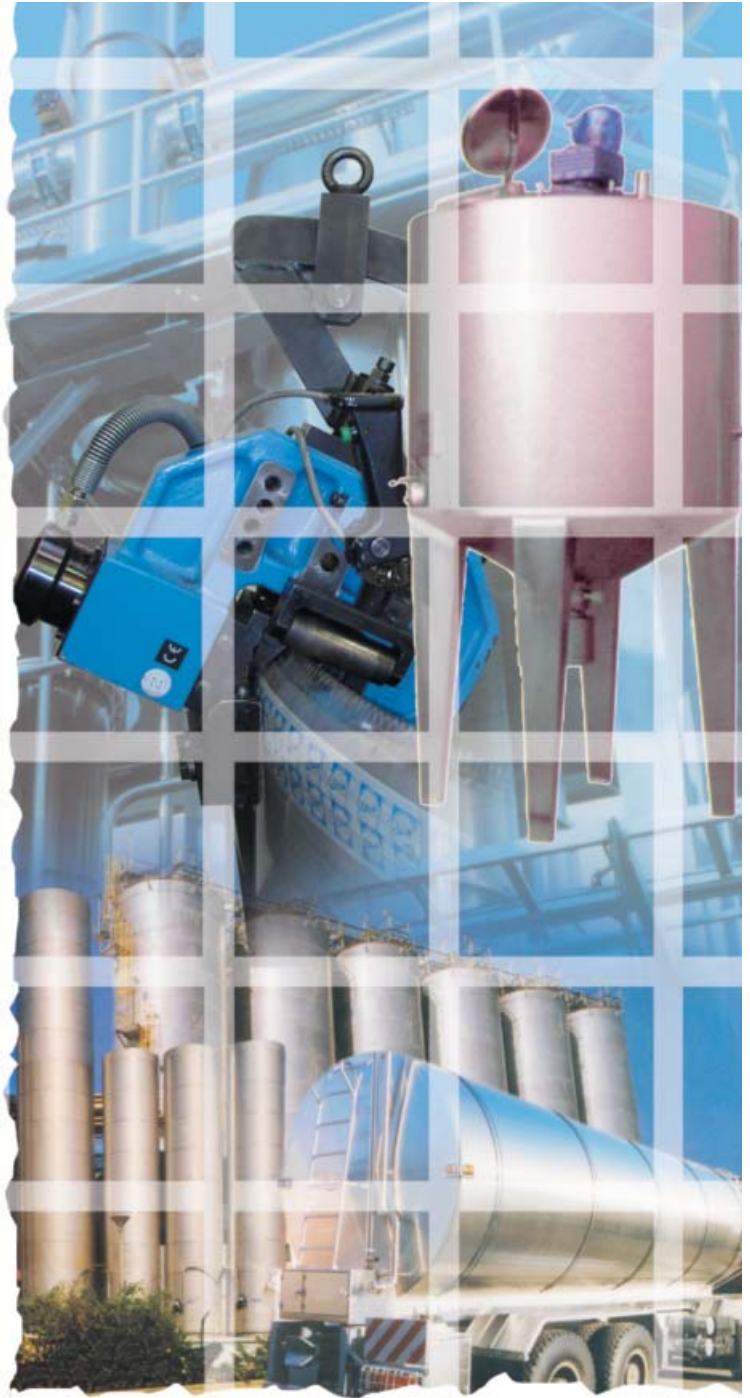

Abbildungen und Masse unverbindlich, technische Änderungen vorbehalten. / Illustrations and technical data are not binding, technical modifications kept under reserve.

Printed in Switzerland • CH11799.200.0090 • PP Mobilformer MZ/MKF • De/En • 05.12



for sheet metal and profiles

Swiss precision

ECKOLD AG

Rheinstrasse 8
CH-7203 Trimmis
Switzerland
Tel.: +41-81 354 12 70
Fax: +41-81 354 12 01
machines@eckold.ch
www.eckold.com

ECKOLD GmbH & Co. KG

D-37444 St. Andreasberg
Germany
Tel.: +49-5582 802 0
Fax: +49-5582 802 300
info@eckold.de
www.eckold.com

ECKOLD Limited

15 Lifford Way
Binley Industrial Estate
GB-Coventry CV3 2RN
Great Britain
Tel.: +44-24 7645 5580
Fax: +44-24 7645 6931
sales@eckold.co.uk
www.eckold.co.uk

ECKOLD & VAVROUCH, spol. s r.o.

Jilemnického 8
CZ-61400 Brno
Czech republic
Tel.: +420 545 24 18 36
Fax: +420 545 24 18 36
eckold@volny.cz
www.eckold.cz

ECKOLD Japan Co. Ltd.

2-14-2, Maihara Higashi
Chiba Pref.
JP-274-0824 Funabashi-City
Japan
Tel.: +81-47 470 2400
Fax: +81-47 470 2402
info@eckold.co.jp
www.eckold.co.jp

