

Handzange HZ 51

Eine Zange für 3 verschiedene Einsatzbereiche: Strecken, Stauchen und Clinchen

Hand pliers HZ 51 - one tool for three different ranges of application: Stretching, shrinking and clinching



® for sheet metal and profiles

HZ 51

Die ECKOLD Handzange HZ 51 ist ideal für Anpass- und Korrekturarbeiten auf der Baustelle. Mit der HZ 51 können Blechprofile oder Flanschanten durch Stauchen oder Strecken angepasst und korrigiert werden. Auch Clinchen ist mit der HZ 51 möglich. Änderungen des Einsatzbereiches einfach durch Werkzeugwechsel.

The ideal tool for adjusting and correcting jobs at the worksite. The hand pliers can be used for correcting or forming metal profiles and sheet flanges by shrinking or stretching and to fasten metal parts by clinching. Changing of the application simply by changing the tools.

Technische Daten

Technical data

Produkt	Handzange	product	hand pliers
Typ	HZ 51	type	HZ 51
Verwendung	Strecken, Stauchen Clinchen	application	stretching, shrinking clinching
Umformbare Blechdicke beim Strecken/Stauchen	max. 1,0 mm St-Qualität max. 1,5 mm Aluminium	Forming capacity for stretching, shrinking	max. 1.0 mm m/s quality max. 1.5 mm aluminium
Ausgelegt für Clinch-Variante	S-Clinch	provided for clinching types	S-Clinch
max. Gesamtblechdicke beim Clinchen	2,0 mm St-Qualität	max. combined material thickness for clinching	2,0 mm m/s quality
Gewicht	» 5.5 kg	weight	» 5.5 kgs

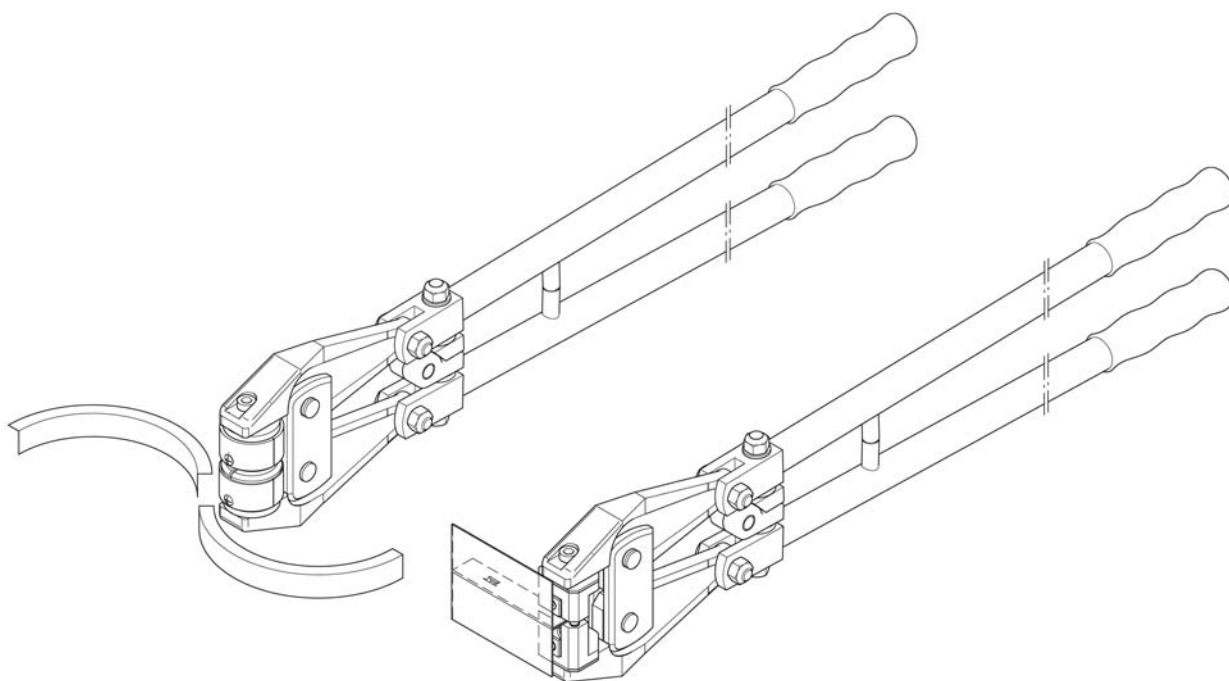

for sheet metal and profiles

Swiss precision

ECKOLD AG
Rheinstrasse 8
CH-7203 Trimmis
Switzerland
Tel.: +41- 81 354 12 70
Fax: +41- 81 354 12 01
machines@eckold.ch
www.eckold.com

ECKOLD GmbH & Co. KG
D-37444 St. Andreasberg
Germany
Tel.: +49-5582 802 0
Fax: +49-5582 802 300
info@eckold.de
www.eckold.com

ECKOLD Limited
15 Lifford Way
Binley Industrial Estate
GB-Coventry CV3 2RN
Great Britain
Tel.: +44-24 7645 5580
Fax: +44-24 7645 6931
sales@eckold.co.uk
www.eckold.co.uk

ECKOLD France
16, rue de la Noue Guimante
Z.I. de la Courtillière
F-77400 St. Thibault-des-Vignes
France
Tel.: +33-1 643 09 247
Fax: +33-1 643 08 192
info@eckold.fr
www.eckold.fr

ECKOLD & VAVROUCH,
spol. s r.o.
Jilemnického 8
CZ-61400 Brno
Czech republic
Tel.: +420 545 24 18 36
Fax: +420 545 24 18 36
eckold@volny.cz
www.eckold.cz

ECKOLD Japan Co. Ltd.
2-14-2, Maihara Higashi
Chiba Pref.
JP-274-0824 Funabashi-City
Japan
Tel.: +81-47 470 2400
Fax: +81-47 470 2402
info@eckold.co.jp
www.eckold.co.jp